

PLAN

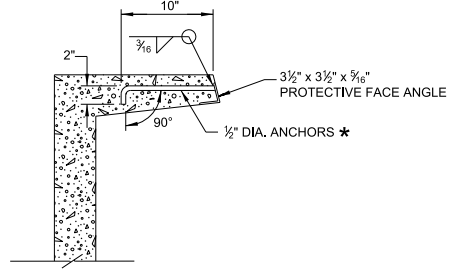

DETAIL E

*ANGLE ANCHORS SHALL BE EMBEDDED MIDPOINT IN EACH ENDWALL, EVENLY SPACED, AND MAXIMUM SPACING OF 5'

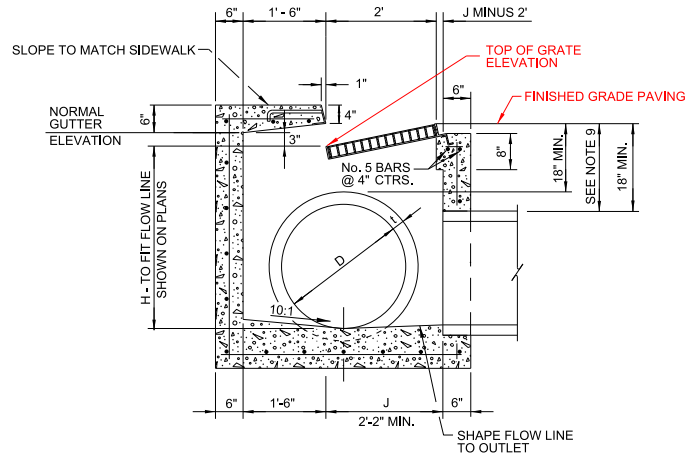
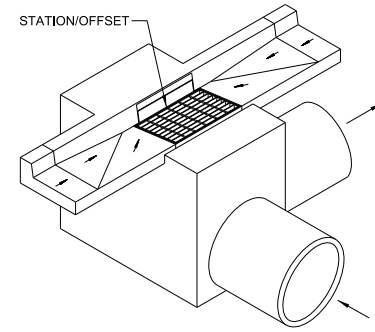

SECTION A-A

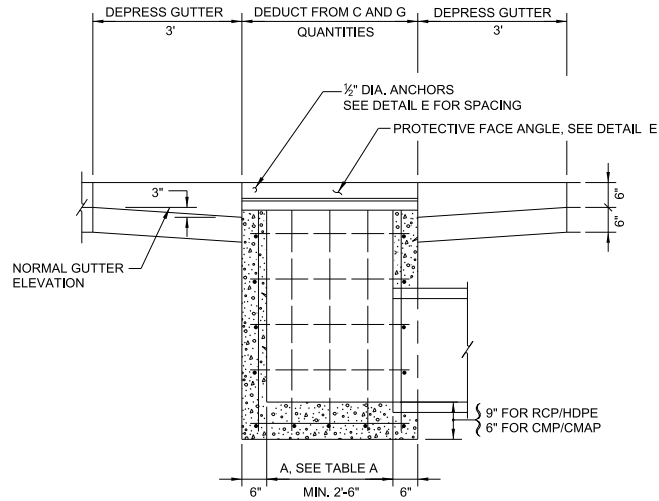

SECTION B-B