

R C P	PIPE SIZE INCH	A	H MIN. FT.	CONCRETE CU. YD.		REINFORCING LB.		STRUCTURAL STEEL LB.
				BASE QUAN. H MIN.	ADD RATE CU. YD./FT.	BASE QUAN. H MIN.	ADD RATE LB./FT.	
H D P E	15"	2'	2.50	0.76	0.19	72	20	358
	18"	2' - 6"	3.00	0.96	0.21	88	22	404
	24"	3'	3.50	1.16	0.23	106	23	450
	30"	3' - 6"	4.00	1.37	0.25	134	26	496
	36"	4'	4.50	1.59	0.26	151	28	542
C M P	42"	4' - 6"	5.00	1.83	0.28	177	29	587
	48"	5'	5.50	2.08	0.30	209	31	633

THE CONCRETE AND REINFORCING QUANTITIES ARE BASED ON THE H MIN. SHOWN, INCREASE THE CONCRETE AND REINFORCING BASE QUANTITY BY THE CORRESPONDING ADD RATE, PER FOOT OF INCREASED H, IF THE H SPECIFIED IS LARGER THAN H MIN.

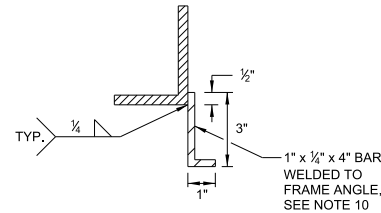

TAB DETAIL

NOTES:

- All concrete shall be class A or AA.
- Reinforcing steel shall be ASTM A 615 grade 60 or A 706 grade 60 No. 4 bars with maximum spacing of 9-inches on center in walls and No. 5 bars with maximum spacing of 12-inches on center in base, wired tightly at all intersections and embedded 2-inches clear of inside surfaces.
- Exposed edges of concrete shall be chamfered 1-4inch.
- Structural steel weight includes the 2.5-inch x-strong pipe, frame angles, grate angles, and 1 x 3/8 bars.
- For drop inlets, configurations with 2 pipes-inflow pipe invert elevation shall be > 0.1-feet above outflow pipe invert elevation.
- For 2.5-4inch diameter XX-strong pipes, see ASTM A53.
- See detail DS-27 for details if connecting HDPE pipe.
- Slope catch basin floors 10:1 from all directions toward outlet pipe. If basin is used as a junction, shape flow line(s) to outlet pipe and provide a 10:1 slope to flow line(s).
- Run rebar continuous thru construction joint. Joint must be a minimum 3-4inches from horizontal bars.
- Weld tabs 6-inches from edge of frame. Eight tabs per grate, two on each side.
- Grate is to fit in the frame and be easily removed. If the gap between the grate and frame is greater than 1/4-inches on each side of the grate, the grate and frame shall be removed and reconstructed to the tolerances specified, or with the approval of the Engineer, a filler strip up to 1/4-inches in thickness may be welded flush to the top of the frame to reduce the gap to a maximum of 1/4-inches.
- Pipe penetrations may be placed in any wall. Interior wall dimensions will limit additional inlet size unless the "A" value and/or "H" value is increased. Pipes larger than 24" OD can not be placed in side walls.
- Contractor to verify "H" values as approved by the Engineer.
- Grate and inlet are designed for 16 kip HL-93 wheel load per "AASHTO LRFD Bridge Design Specifications 2012". Live load impact and multiple presence factors are not applied.

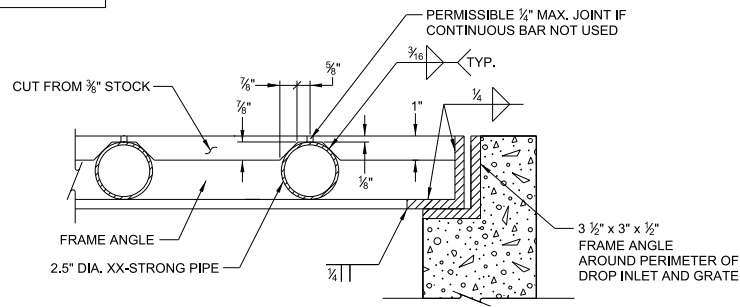

DETAIL A

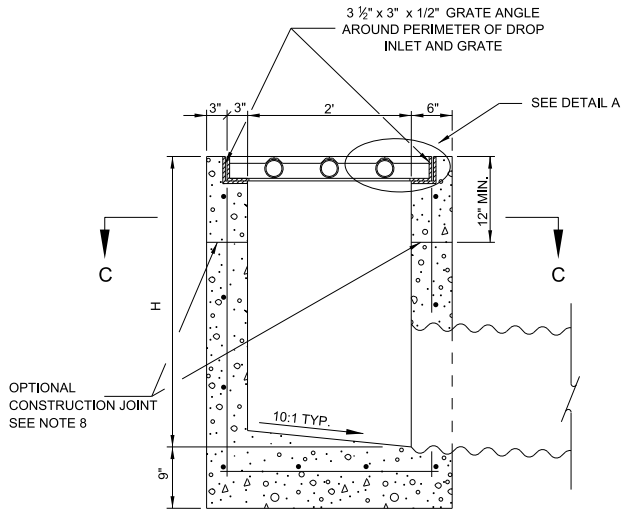

SECTION A-A

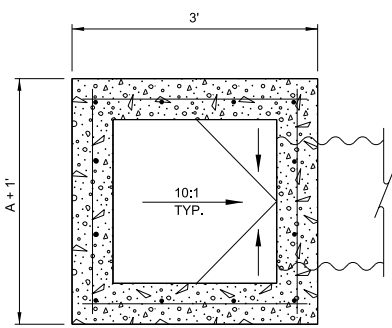

SECTION C-C

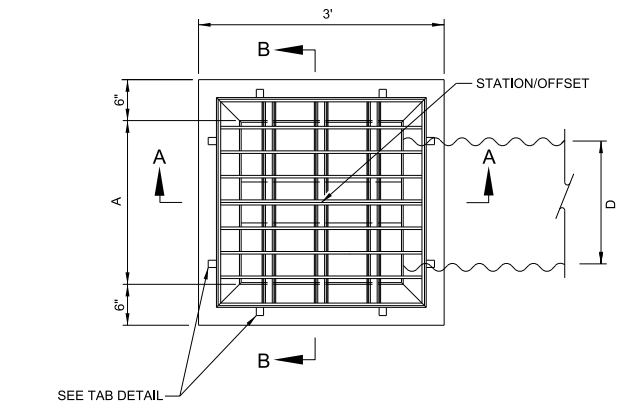

PLAN

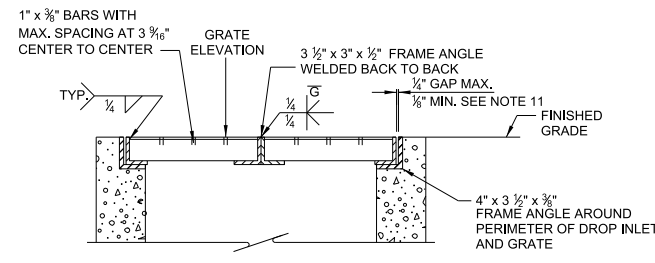

SECTION B-B

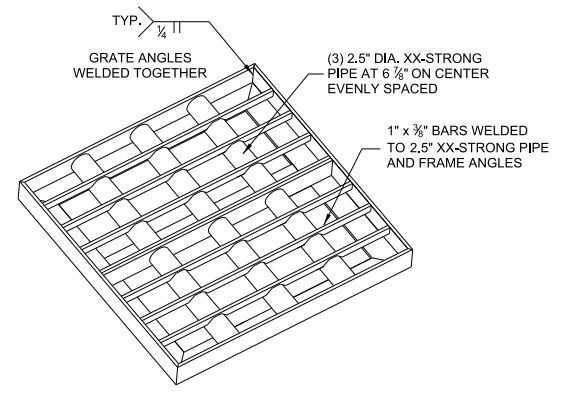

GRATE DETAIL